

# Sub-critical Thorium reactors

Carlo Rubbia  
CERN, Geneva, Switzerland  
Aker Solutions, United Kingdom

## Traditional nuclear fission ?

- Nuclear energy is produced whenever a light nucleus is undergoing fusion or a heavy nucleus is undergoing fission.
- Today's nuclear energy is based on U-235, 0.71 % of the natural Uranium, fissionable both with thermal and with fast neutrons.
- At the present consumption rate ( $\approx 6\%$  of primary energy), U reserves are about comparable with those of Oil and NG.
- In the Sixties, "Atoms for Peace" had promised cheap, abundant and universally available nuclear power, where the few "nuclear" countries would ensure the necessary know-how to the many others which had renounced nuclear weaponry.
- Today, the situation is far from being universally acceptable: the link between peaceful and military applications has been shortened by the inevitable developments and the corresponding widening of the know-how of nuclear technologies.
- For nuclear energy to become freely and more abundantly available in all countries, some totally different but adequate nuclear technology must be developed.

# New, virtually unlimited forms of nuclear energy

- Particularly interesting are fission reactions in which a natural element is firstly bred into a readily fissionable element.

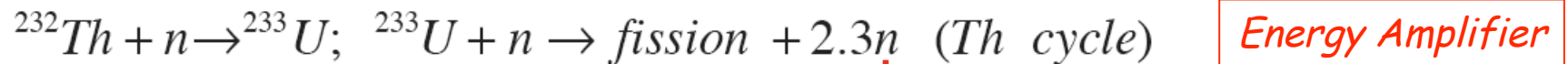

Energy Amplifier

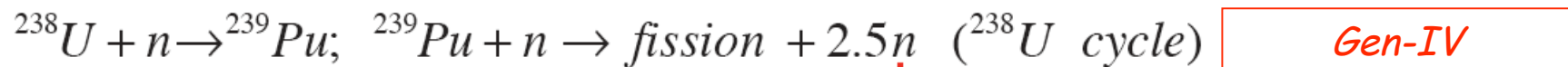

Gen-IV

- The main advantage of these reactions *without U-235* is that they may offer an essentially unlimited energy supply, during millennia at the present primary energy level, quite comparable to the one of Lithium driven D-T Nuclear Fusion.
- However, they require substantial developments since :
  - ⇒ two neutrons (rather than one) are necessary to close the main cycle
  - ⇒ the daughter elements (U-233 and/or Pu-239) do not exist in nature but they can be generated after initiation

# New features of Breeders

- Breeding reactions have considerable advantages with respect to present thermal reactors based on either enriched or natural U-235.
  - ⇒ Enrichment is no longer necessary, since they use entirely the bulk natural material, either Thorium or Uranium.
  - ⇒ The whole element is converted to fissionable, yielding a  $\approx 200$  times larger energy than the one currently available with U-235.
  - ⇒ The average crust densities are 8. g/t for Thorium and 2. g/t for Uranium; unfortunately most of the Uranium is dissolved inside the sea, while Th is a underground mineral.
  - ⇒ The "waste" consists primarily of the intense but short lived fission fragments (Sr-90: 29.1 y; Cs-137:30.1 y) while the much more long-lived Actinides are "recycled".

# Proliferation issues

- Unfortunately the breeding reaction on Uranium is badly proliferating, since it implies the vast production of Plutonium;
- Instead the breeding reaction on Thorium is largely immune from proliferation risks;
  - ⇒ the three main elements of the discharge, if chemically separated, namely U, Np and Pu (Pu-238) exclude the feasibility of an explosive device (CM= critical mass)

Element	Bomb grade Pu-239	Uranium (U-232)	Neptunium <sup>(3)</sup> (Np-237)	Plutonium <sup>(3)</sup> (Pu-238)
Critical mass (CM), kg	3	28.0	56.5	10.4
Decay heat <sup>(1)</sup> for CM, Watt	8	380	1.13	4400
Gamma Activity, Ci/CM	negligible	1300	small	small
Neutron Yield <sup>(2)</sup> , n g <sup>-1</sup> s <sup>-1</sup>	66	3000	2.1 10 <sup>5</sup>	2600

*U-232 (2x10<sup>3</sup> ppm) contam. in a U-233 critical mass due to Tl-208 (2.6 MeV) is about 72 Sv/h : (50% lethal dose after 5 minutes)*

(1) Equilibrium temperature  $\approx 190$  °C for 100 W, due to presence of HP explosive shield

(2) Neutron yield must be  $\leq 1000$  n g<sup>-1</sup> s<sup>-1</sup>

(3) Very small amounts produced at discharge

- ⇒ The long duration of the fuel cycle (10 y) permits to keep it sealed under international control, avoiding an illegal insertion of any other possible bomb-like materials

# Fission Breeders

- In the steady elementary breeding process, the actual number  $\eta$  of neutrons necessary in the fuel for each neutron absorbed in the fissile isotope must exceed significantly 2 in order to allow for the inevitable losses in the process due to captures in the other materials, escapes and so on.

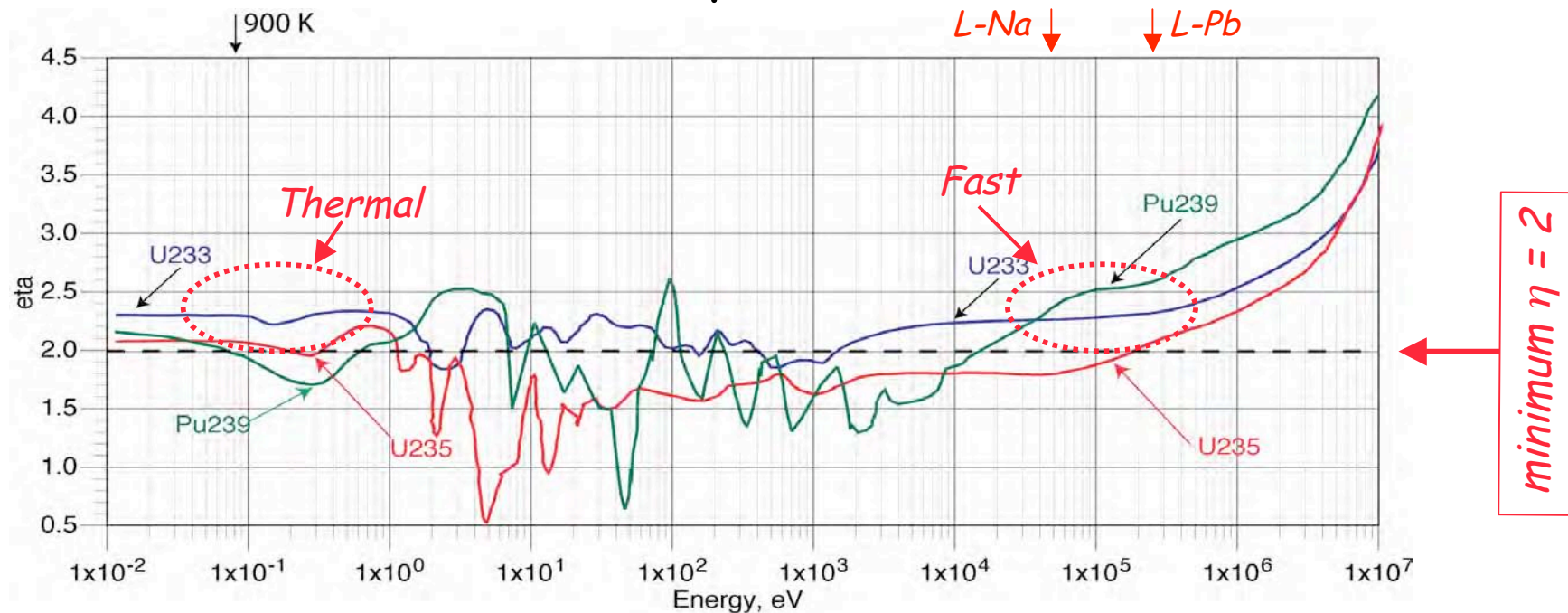

- The U-238 breeder has  $\eta > 2$  only for fast neutrons
- The Th-232 breeder has  $\eta > 2$  both with thermal and fast n

# The need for a new concept: an Accelerator driven system

- This very small neutron excess is essentially incompatible with the requirements of any critical reactor without U-235. An external neutron source must be added to ensure the neutron inventory balance. This is both true for Fission (Th and/or Depleted U) and D-T Fusion starting from Lithium.
- The development of modern accelerators has permitted the production of a substantial neutron flux with the help of a proton driven high energy spallation source.
- Let  $k_{eff}$  be the neutron multiplication coefficient of an ADS ( $k_{eff} = 1$  for a critical reactor). In a "sub-critical" mode,  $k_{eff} < 1$  neutrons are produced by a spallation driven proton beam source and multiplied by fissions. The nuclear power is then directly proportional to the proton beam power with a gain  $G$ :

$$G = \frac{\chi}{1 - k_{eff}} \quad ; \chi \approx 2.1 \div 2.4 \text{ for } Pb - p \text{ coll. } > 0.5 \text{ GeV}$$

$$G = 70-80 \text{ for } K_{eff}=0.97 \text{ and } G = 700-800 \text{ for } K_{eff} = 0.997 \text{ (very large)}$$

# Critical(reactor) and sub-critical (energy amplifier) operation

## Chain Reaction

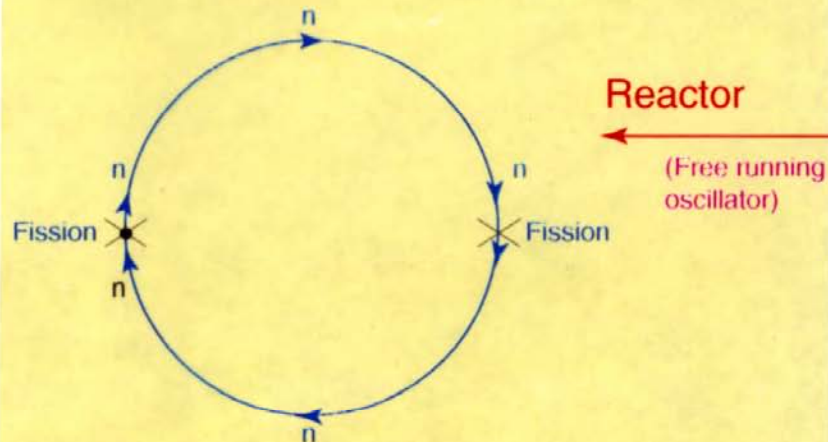

Self sustained process

⇒ Time derivative of produced power kept 0 by control

Critical reactor: prompt criticality divergent (Chernobyl)

## Nuclear Cascade

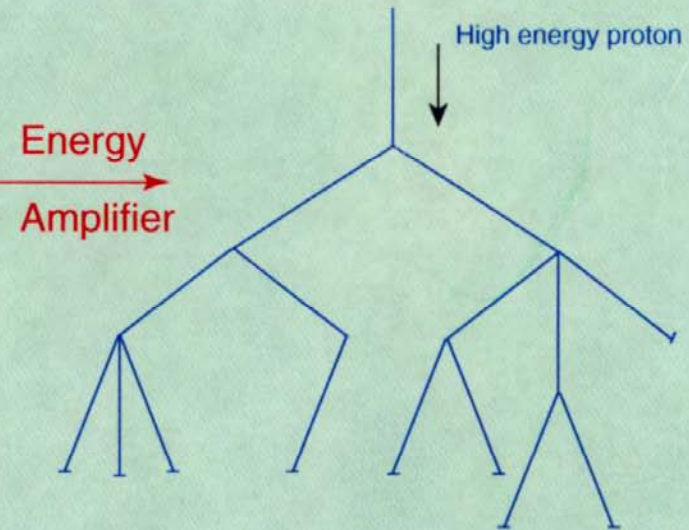

Over-compensator calorimeter

Externally driven process

⇒ Constant "Gain"

Particle beam driven EA

$$E_{\text{tot}} = G \times E_p$$

Produced Power      Beam Power

# A prolific neutron source: the proton spallation in a heavy Z

- Modern proton accelerators on a heavy Z target (Lead) produce a very large number of neutrons.
- For a proton energy of 1 GeV and 1.5 GWatt thermal power we need:
  - ⇒  $2.7 \cdot 10^{20}$  fission/s ( $K_{eff} = 0.997$ ,  $G=700$ )
  - ⇒  $3.8 \cdot 10^{17}$  spallation neutrons/s (30 n/p)
  - ⇒  $1.3 \cdot 10^{16}$  protons/s
  - ⇒ Current: **2.12 mA**

Compare: PSI proton cyclotron:  
590 MeV, 72 MeV injection  
2mA, 1 MWatt

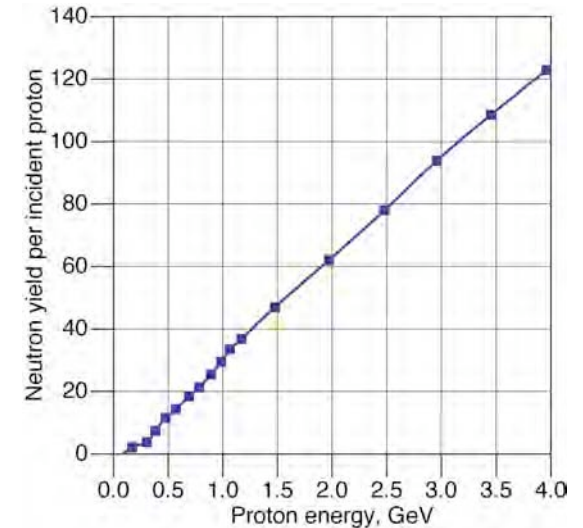

## Accelerator requirements and reliability

- The spallation target is the most innovative element of the Energy Amplifier.
- High currents are within the possibilities of modern accelerators, either Cyclotrons or superconducting LINACs.
- Reliability is the most important new aspect of an otherwise within the state of the art realization.
- It should be easily achieved through redundancy of the separate components: no more than few beam trips per year



Cyclotron

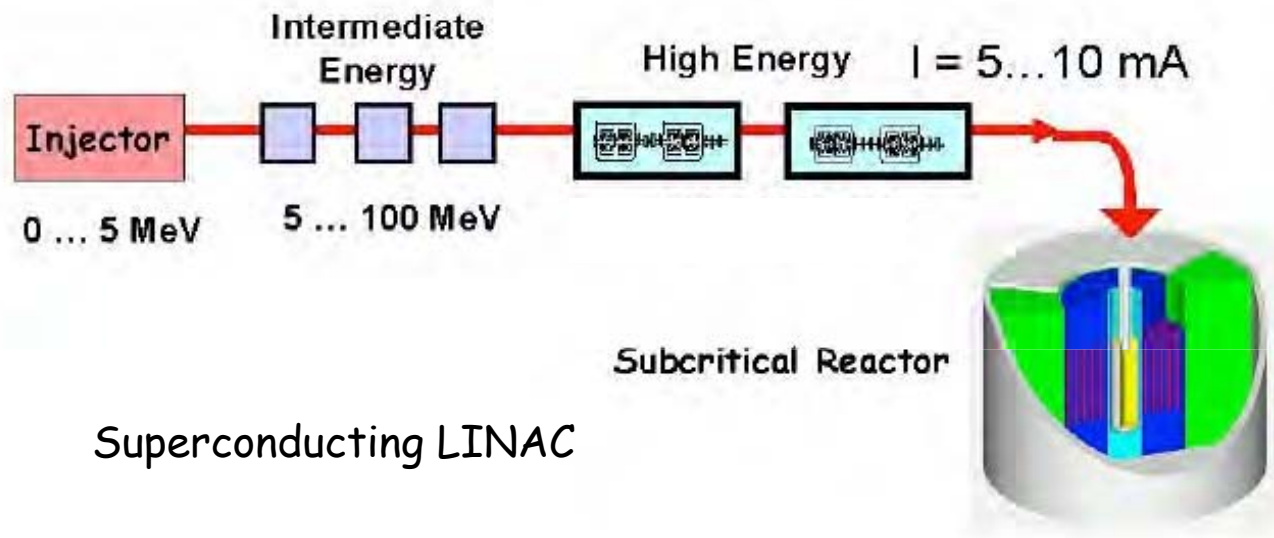

# Principle of operation of the Energy Amplifier

- The process is based on two steps:
  - ⇒ Non fissile Thorium is transformed into fissile U-233 with the help of a first neutron:
  - ⇒ Fissile U-233 is fissioned by a second neutron, with large energy production the emission of 2.3 new additional neutrons which continue the process.
- A particle accelerator is supplying the missing neutron fraction and it controls the energy produced in the reaction.
- At the end of a cycle the fuel is reprocessed and the only waste are **Fission Fragments** Their radio-activity is intense, but limited to some hundred years.
- **Actinides** are recovered without separation and are the "seeds" of the next load, added to fresh Thorium.
- *The cycle is "closed" in the sense that the only material inflow is the natural element and the only "outflow" are Fission Fragments.*

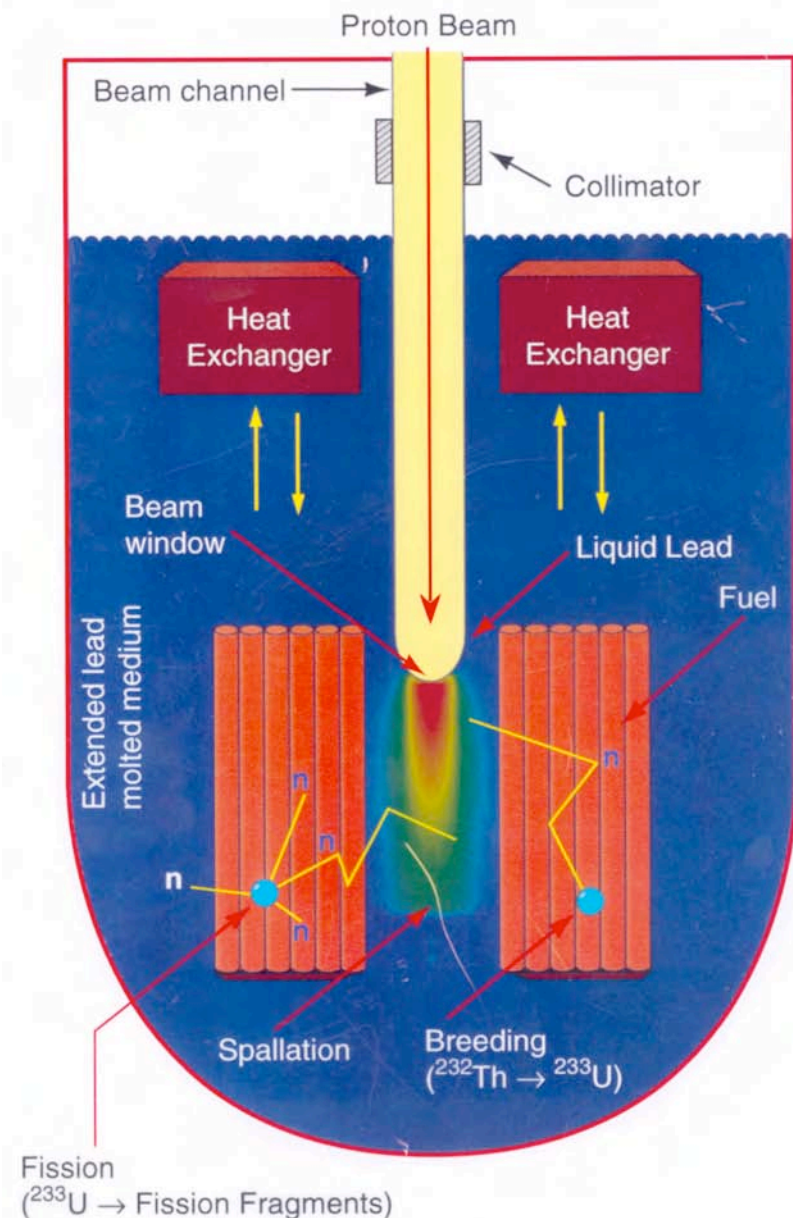

# Feasibility Study: Aker ASA and Aker Solutions ASA

- 1500MWh/600MWe
- Sub-critical core
- Thorium oxide fuel
- Accelerator driven via central beam tube
- Molten lead coolant
- Coolant temp 400-540°C
- 2 Axial flow pumps
- 4 Annular heat exchangers
- Direct lead/water heat exchange

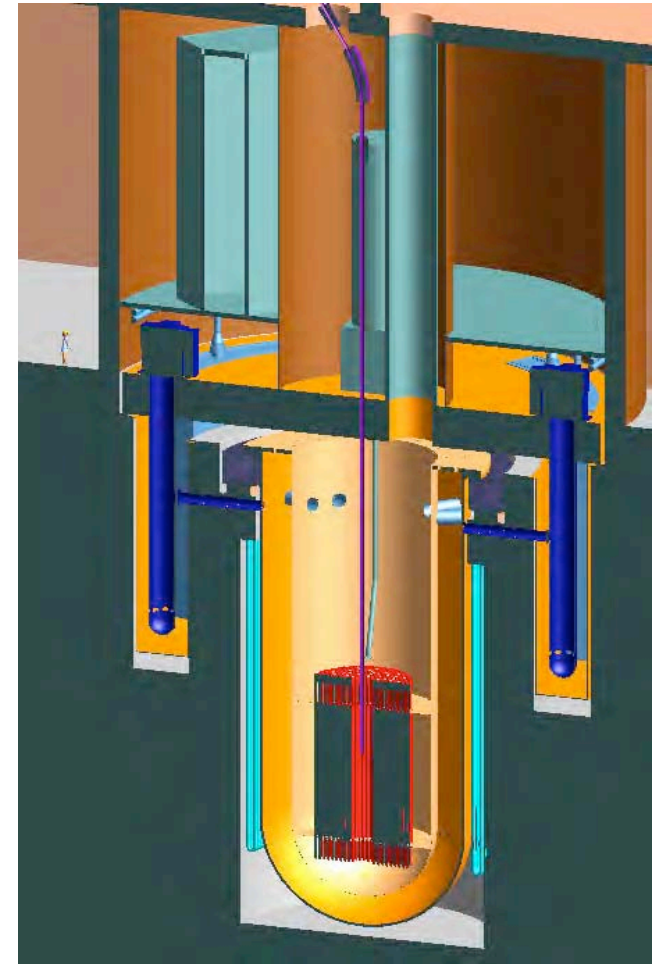

A Thorium fuelled reactor for power generation

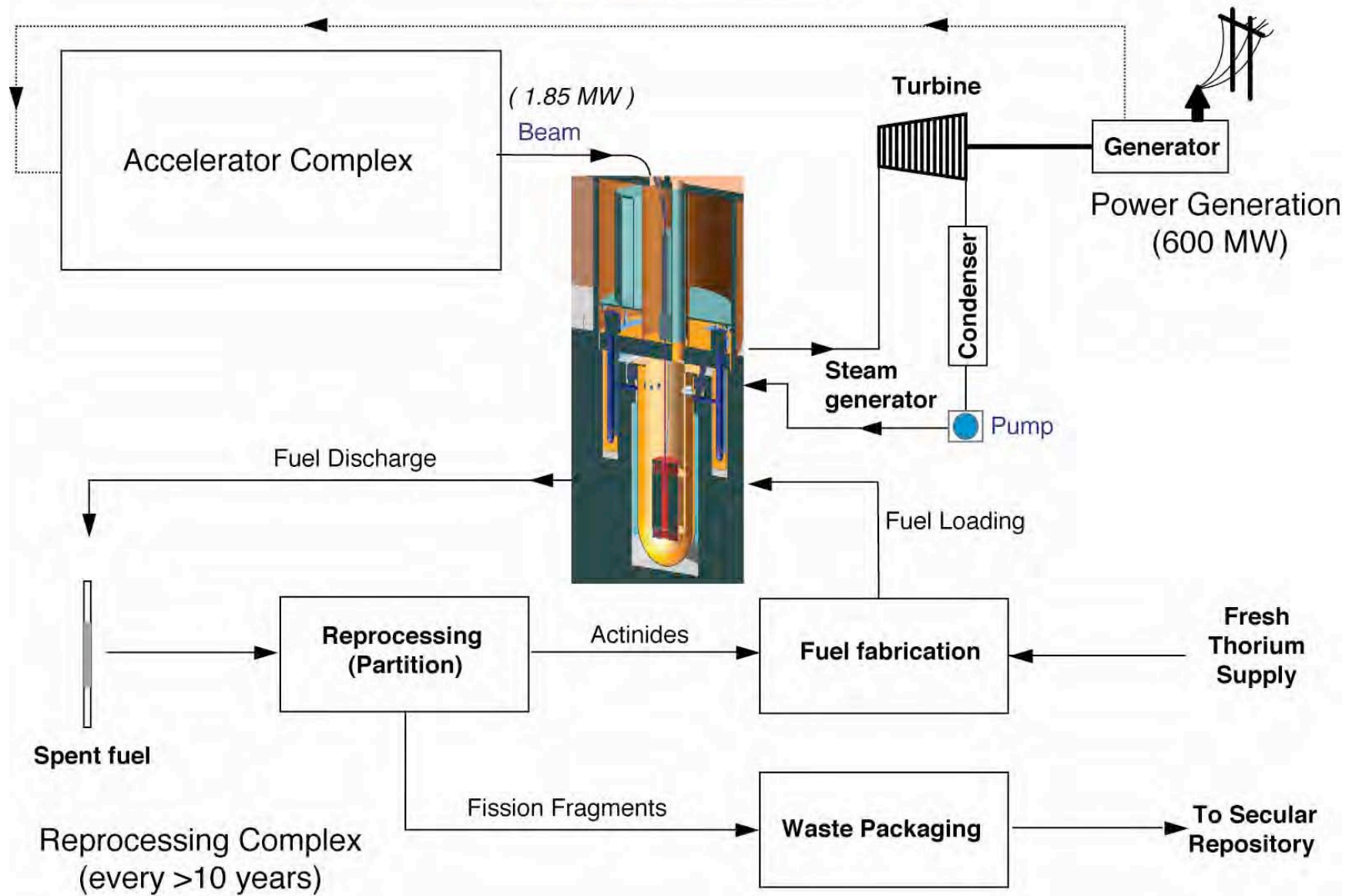

# Plutonium elimination and Uranium Fissile buildup

- Metal content of Plutonium, U-233, all Uranium isotopes and Pa-233 as a function of the burn-up for 11 successive cycles: from [a] to [l]
- The initial fuel is a MOX mixture with of 84.5 % of  $ThO_2$  and 15.5% of  $PuO_2$ .
- At the end of each cycle, about 10 y long, all Actinides are reprocessed and burnt: fresh Th-232 is refilled.
- New cycle is started slightly below the breeding equilibrium, to maintain k losses compensation constant to less than  $\pm 0.5\%$  during the whole burn-up interval and over many years.

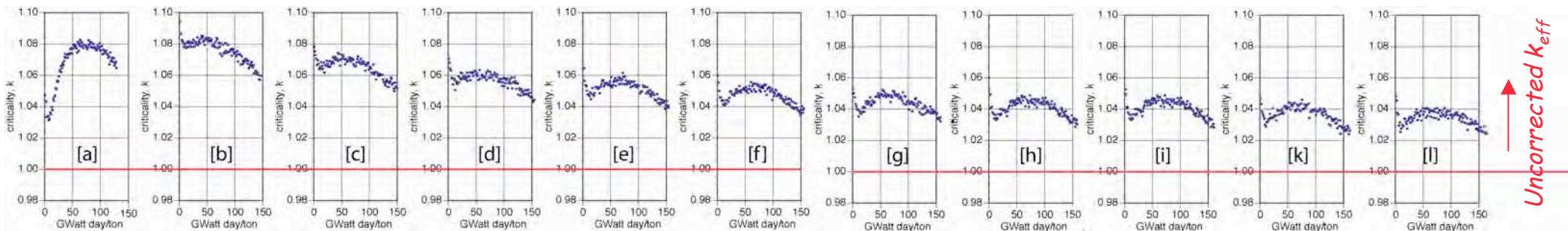
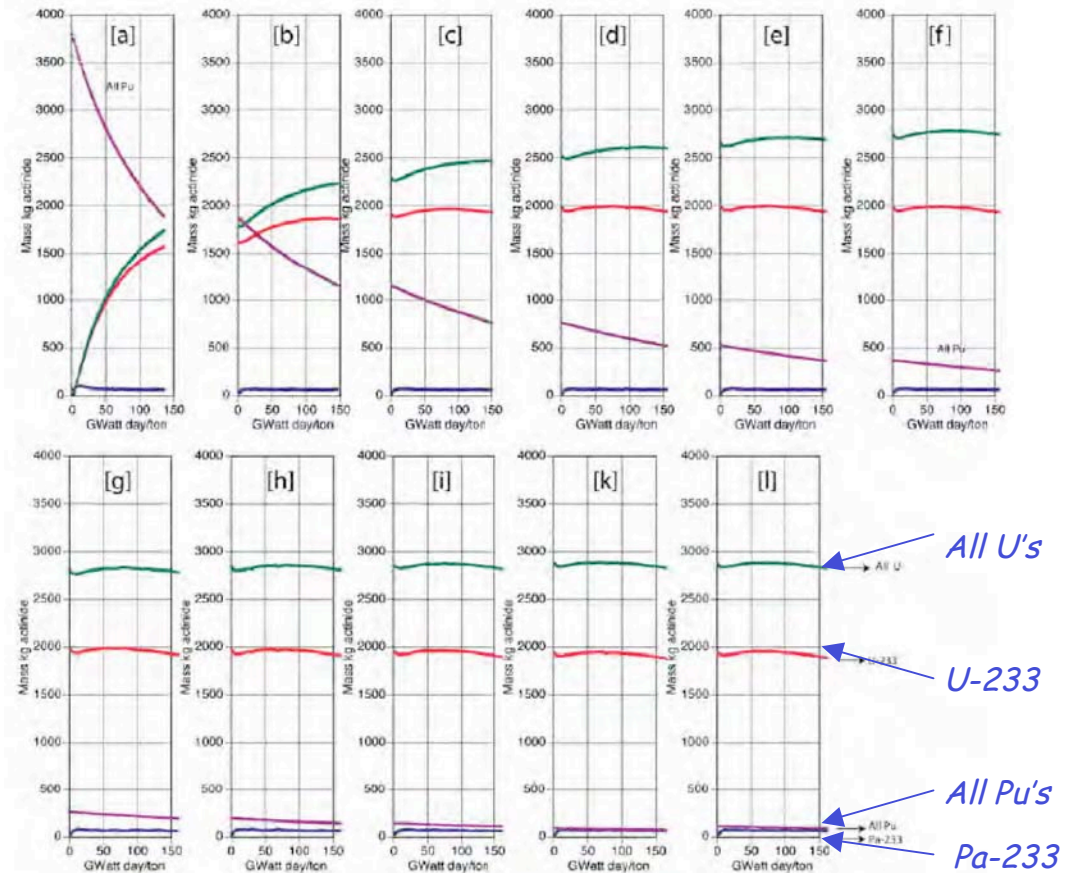

# Residual radio-toxicity of waste as function of time

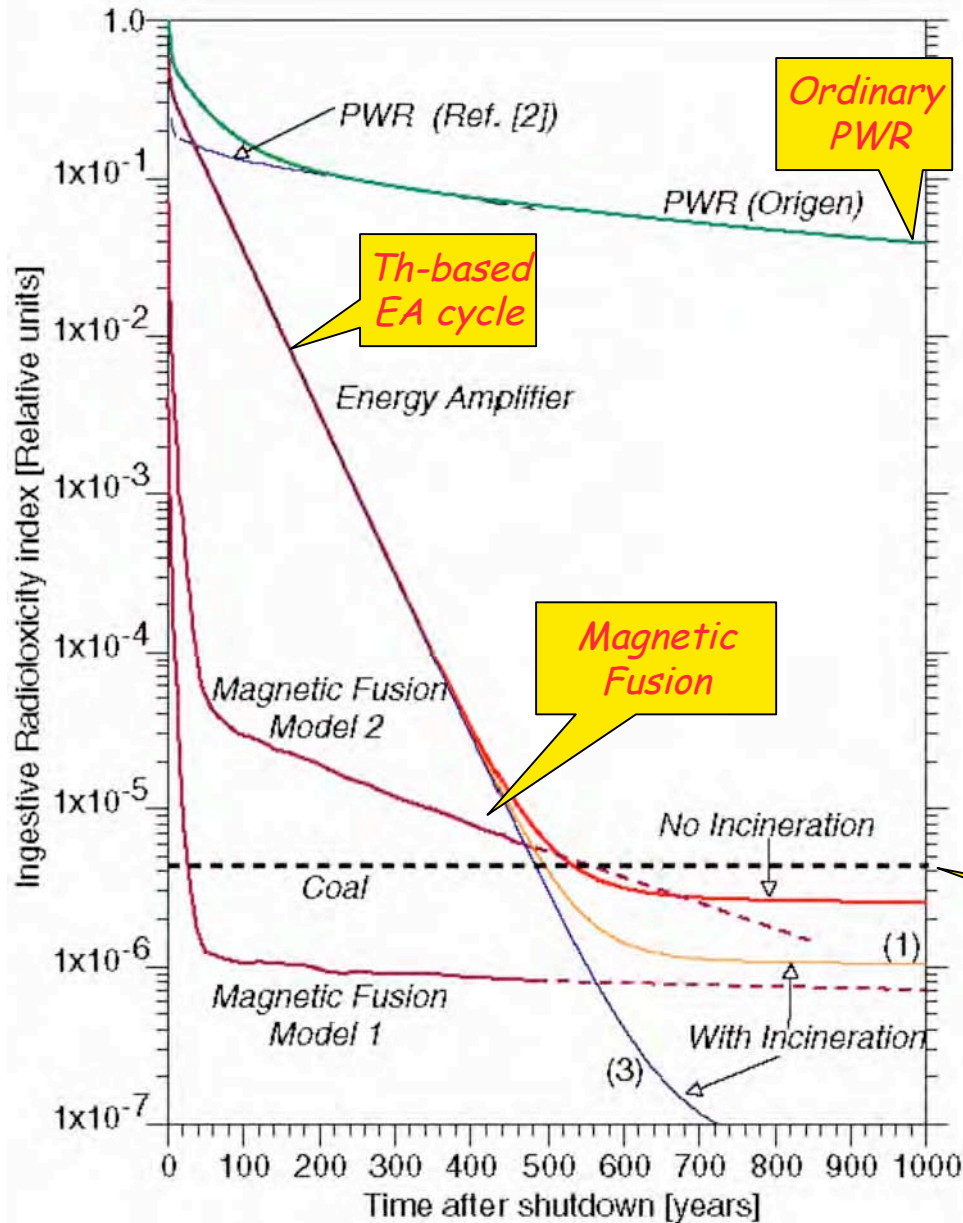

Comparing :

(1) ordinary reactor (PWR)

(2) Thorium based EA

(3) two T-D fusion models

Waste may return to the environment

# Comparing alternatives

To continuously generate a power output of 1GW for a year requires:



3,500,000 tonnes of coal

Significant impact upon  
the Environment  
especially  $CO_2$  emissions



200 tonnes of Uranium

Low  $CO_2$  impact  
but challenges with  
reprocessing  
and very long-term  
storage of hazardous  
wastes  
*Proliferation*

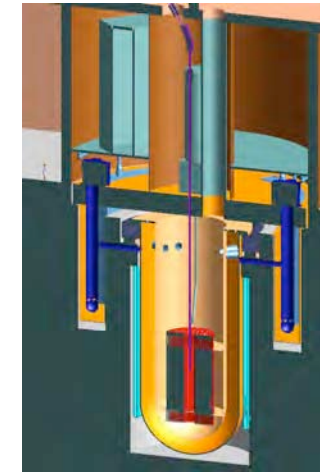

1 tonne of Thorium

Low  $CO_2$  impact  
Can consume Plutonium and  
radioactive waste  
Reduced quantity and much  
shorter duration for  
storage of hazardous  
wastes  
*No proliferation*

# Conclusions:

<b>Item</b>	<b>Energy Amplifier</b>
Safety	Not critical, no meltdown
Credibility	Proven at zero power
Fuel	Natural Thorium
Fuel Availability	Practically unlimited
Chemistry of Fuel	Regenerated every 10 years
Waste Disposal	Coal like ashes after 600 y
Operation	Extrapolated from reactors
Technology	No major barrier
Proliferating resistance	Excellent, Sealed fuel tank
Cost of Energy	Competitive with fossils

**Thank you !**

# Molten salt systems (Alvin Weinberg)

- Liquid Fuel:  $\text{LiF}$ ,  $(\text{NL})\text{F}_4$ ,  $\text{BeF}$ :
- NL from 6,5% to 20 %.
- Volume :  $20 \text{ m}^3$ , Temp.:  $630^\circ\text{C}$ ,
- Power :  $2.5 \text{ GW}_{\text{th}} = 1 \text{ GW}_{\text{ele}}$
- Critical or sub-critical ?
- A molten salt reactor's fuel is continuously reprocessed by an adjacent chemical plant on line. *All the salt has to be reprocessed every ten days.* The reprocessing cycle is based on **fluorination**:
  - ➔ Fluorine removes  $\text{U}233$  from the salt.
  - ➔ A molten bismuth column separates  $\text{Pa}233$  from the salt before decay.
  - ➔ A fluoride-salt distillation system distills the salts. Each salt has a distinct temperature of vaporization.
  - ➔ The light carrier salts evaporate at low temperatures, and form the bulk of the salt.
  - ➔ The thorium salts must be separated from the FP which become "waste"
- The amounts recovered are about 800 kg of waste per year per GW generated.

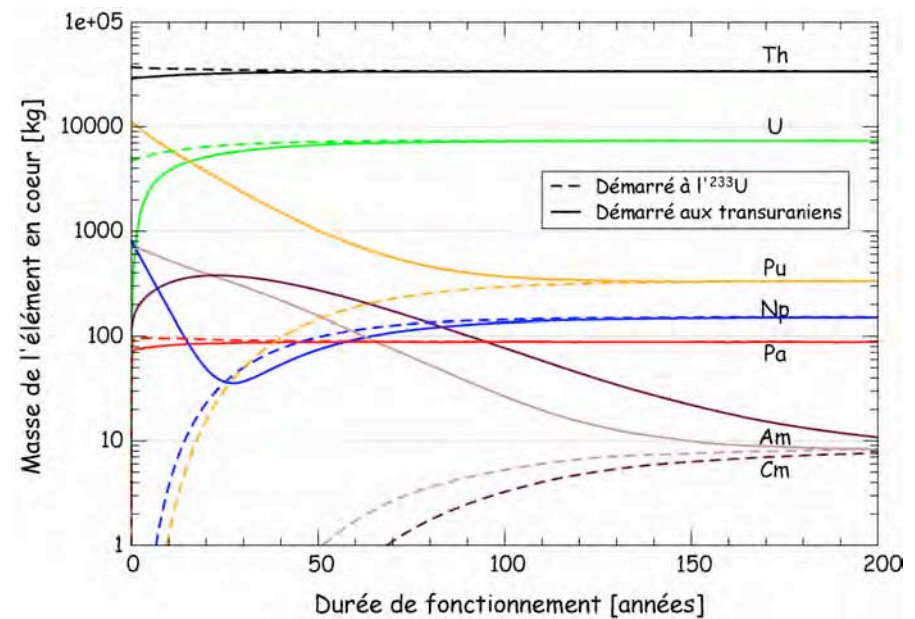
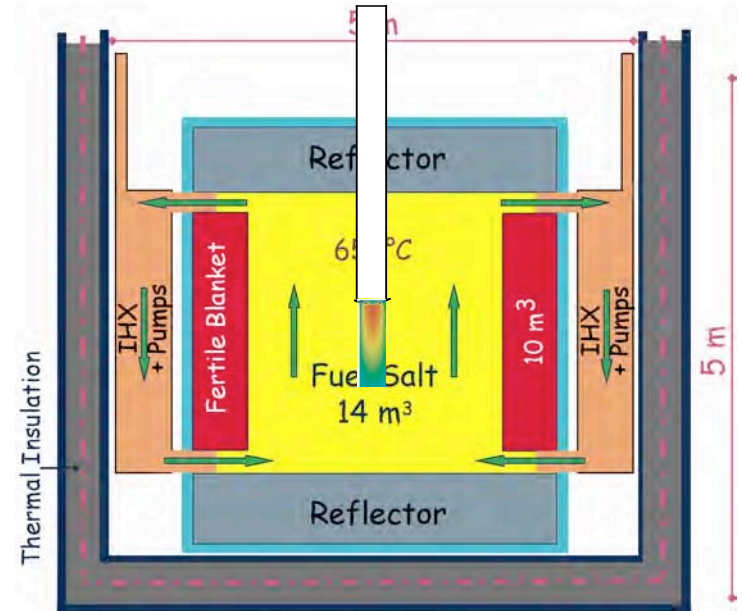

# Transmutation of minor actinides

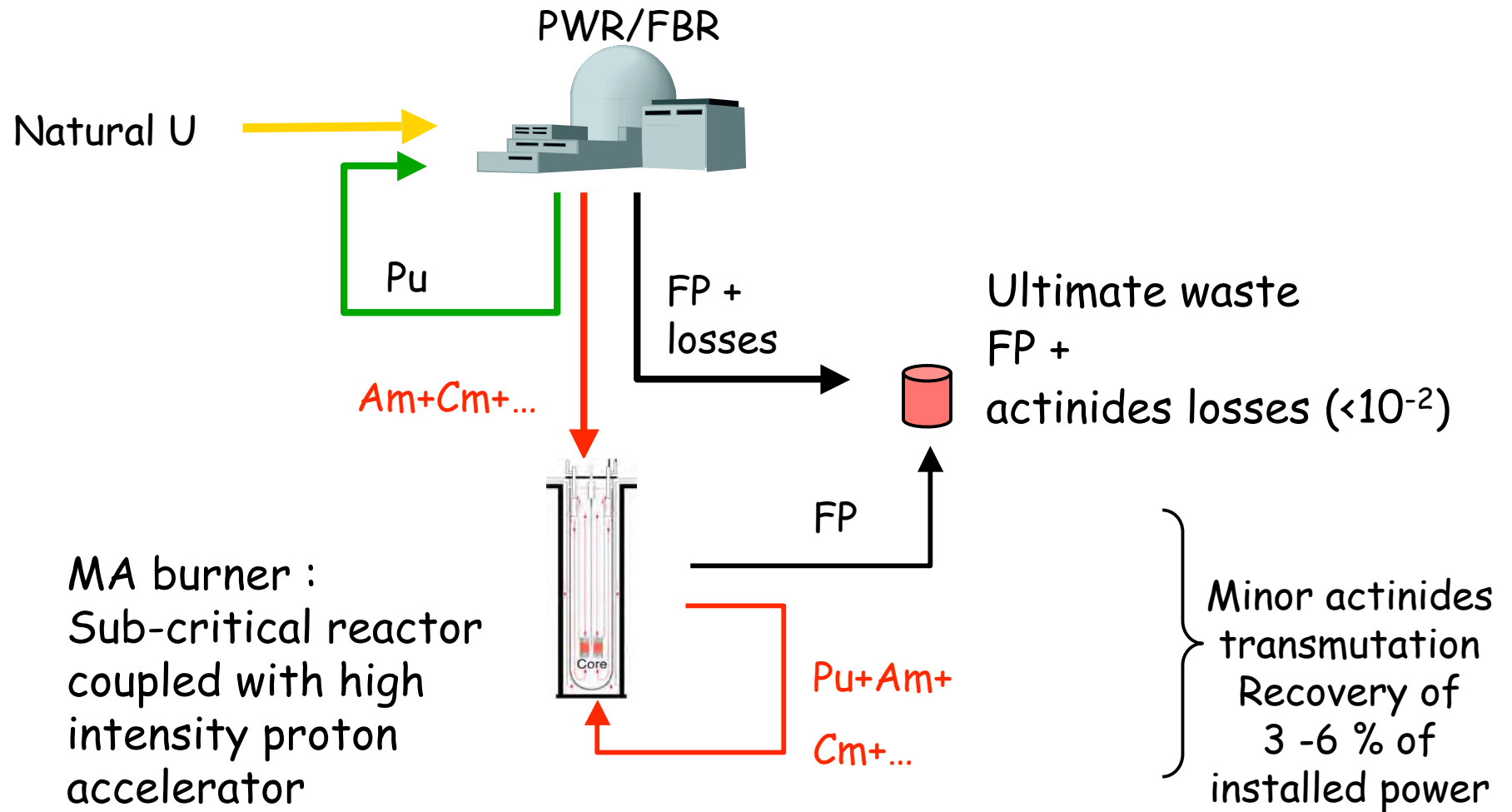

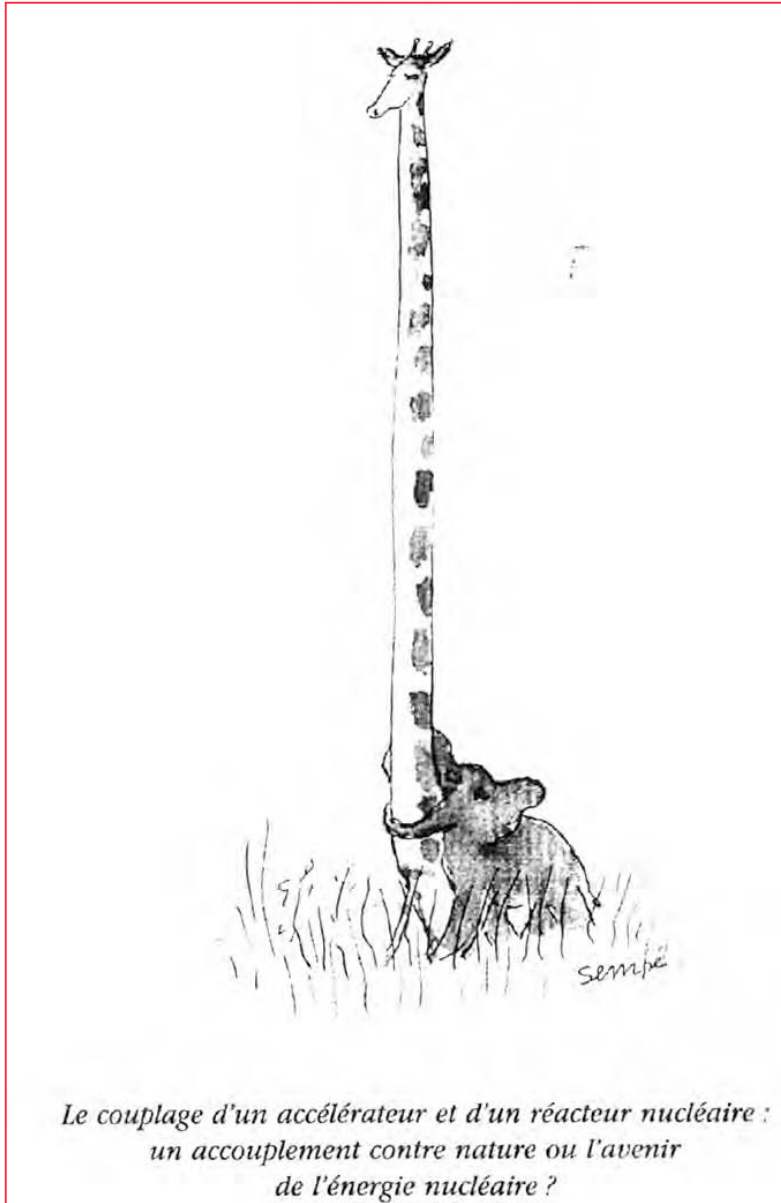

*The coupling of an accelerator and  
of a nuclear reactor:  
a mating against nature or the  
future of the nuclear energy ?*